



CTDI Products: End-to-End Solutions

MicroNode™ 120 RFoG ONU

The CTDI **MicroNode 120 Forward and Return Path RFoG ONU** delivers advanced bi-directional, interactive RF services over a passive fiber optic distribution network. It is designed to operate on the same fiber as a working Passive Optical Network (PON) access/distribution system, giving you the flexibility to support all voice, video and data services on a common infrastructure. The MicroNode 120 RFoG ONU provides the freedom and flexibility to work with any PON solution that uses industry standard optical wavelengths, and serves as the optical transport layer for RF video, DAVIC, or DOCSIS technologies. By extending the optical network directly to a home or building, the MicroNode 120 RFoG ONU eliminates neighborhood HFC nodes. This not only removes the costs of the annual testing and maintenance required to operate the HFC nodes, but also the ongoing power requirements of the nodes and RF amplifiers. The MicroNode RFoG ONU provides bi-directional services over extended RF frequencies (up to 1.1Ghz) while being agnostic to both headend and customer premises equipment (CPE), and preserving today's operating processes. CTDI's MicroNode 120 RFoG ONU: flexibility to grow your network to meet customer demand now and in the future.

Benefits

- Reduces network costs via elimination of HFC nodes
- Allows deployment of fiber optic distribution network while leveraging existing RF and DOCSIS investments
- Compatible with industry standard BPON, GPON and EPON systems
- Universal support for headend and CPE equipment
- High performance, ultra low noise burst mode enables use of full RF spectrum for the return path, resulting in increased available bandwidth
- Low maintenance and high reliability of an all-fiber network
- Reduced power consumption via green technology

Features

- Extended spectrum RF video
- Analog & digital video formats
- Universal HFC set top box, cable modem and headend support
- Transparent return path capability (protocol and modulation format agnostic)
- Optical AGC with positive RF up-slope
- Supports in-home applications without amplifiers
- In-home power over 75 Ohm coax cabling
- Ultra low ingress noise performance



CTDI Product Sales ~ 866-953-9030 ~ www.CTDI.com



MicroNode™ 120 RFoG ONU

Specifications

Physical

- 1.2" H x 3.5" W x 5" D
3.0cm H x 8.9cm x W 12.7cm D
- 7.5oz / 0.2kg

Indicators/External Alarms

- Green LED power indicator
- Red LED loss of signal indicator

Optical Interface

- 1 recessed SC/APC female fiber connector

Customer Interface

- 75 Ohm coax "F" connector

Downstream Characteristics

- Input wavelength: 1540-1565nm
- Input power range: 0 to -6dBm
- Loss of optical power alarm: < -11dBm
- RF Output @ 550MHz:
+18dBmV/ch ±2dBmV
- Frequency response:
MNTH126: 50MHz to 1.1GHz
MNTH127: 88MHz to 1.1GHz
- Flatness: ±1dB
- Up-tilt 50MHz/88MHz to 1.1GHz: 3dB
- CNR @ -6dBm input power: 48
- CSO @ 0dBm input power: 60
- CTB @ 0dBm input power: 60

Return Path Characteristics

- Class 1 laser
- Wavelength: 1610 ±10nm
- Output power: +2dBm to +4dBm
- Input dynamic range:
+15dBmV to +40dBmV
- Frequency response:
MNTH126: 5MHz to 42MHz
MNTH127: 5MHz to 65MHz

Flexible Installation

- Operate on a single PON fiber architecture
- Installs into any CTDI home ONT enclosure
- Temperature-hardened

Power and Environmental

- Operating temperature: -40°C to +65°C
- Humidity: 5% to 95% non-condensing
- Power input voltage: 10 to 16VDC (12VDC nominal)
- Power consumption: 3 watts max
2.3 watts typical

Standards and Certifications

- UL listed, CE mark certified
- Meets or exceeds FCC part 15b
- IEC 608251:1993+A1:1997+A2:2001
- 2004/108/EC

Ordering Information

Part #	Description
MNTH126	MicroNode 126 RFoG ONU (42MHz/1610nm RP)
MNTH127	MicroNode 127 RFoG ONU (65MHz/1610nm RP)

Power

The following CTDI power supplies may be used to operate MicroNode 120 RFoG ONUs.

Part #	Description
PSB8000	12VDC, 24W UPS (Charger & 7.2AH battery)
PSB8002	12VDC, 24W UPS hardened (Charger & 7.2AH battery)
PSB1005	12VDC, 24W brick, plug-mounted
PSB1006	12VDC, 24W brick, international plug-mounted
PSB1007	12VDC, brick, plug-mounted, coax feed
PSB1008	12VDC, brick, international plug-mounted, 5mm barrel plug
PSB1009	12VDC, 30W hardened UPS for OSPE202 (240VAC)
PSB1010	12VDC, 30W hardened UPS for OSPE202 (120VAC)
BAT1002	12VDC, 7.2AH battery for OSPE202 and PSB8000 series

Mounting

The MicroNode 120 transceivers may be mounted directly on an interior wall or into any of the following CTDI enclosures.

Part #	Description
OSPE110	Enhanced plastic outside enclosure
OSPE120	Plastic outside enclosure with NID
OSPE202	All-in-One metal outside enclosure
OSPE301	MicroNode standard outside enclosure

Hybrid RF PON

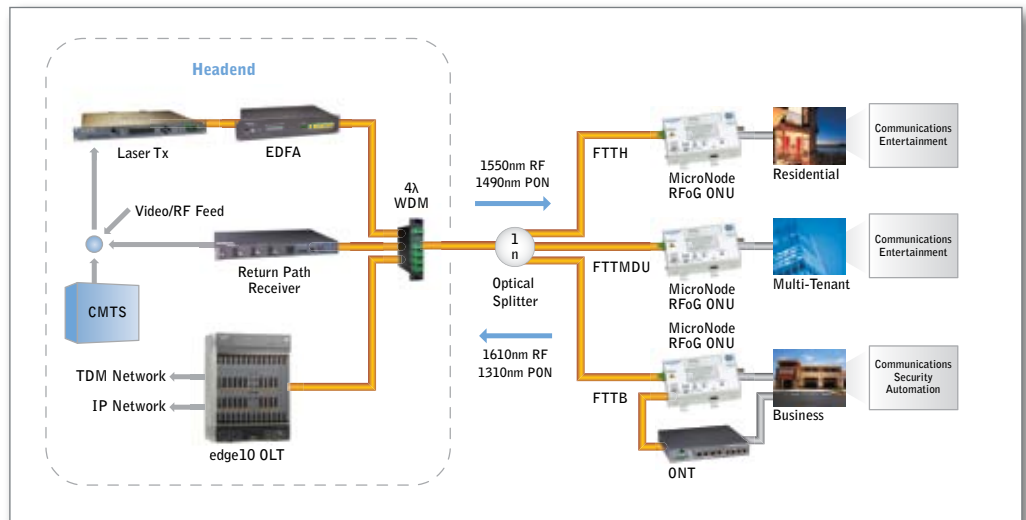

- EN55022, EN55024, EN50083, EN61000-3 & EN60950
- RoHS
- SCTE 55-1, 55-2
- Compatible with DAVIC & DOCSIS
- SCTE IPS SP910



PRODUCTS

Communications Test Design, Inc.
1373 Enterprise Drive • West Chester, PA 19380
610.436.5203 • www.ctdi.com

©2010 CTDI. All rights reserved.
Class 1 Laser Products. Information subject to change without notice. • REV042310