



CTDI Products: End-to-End Solutions

## MicroNode™ 130 RFoG ONU

The CTDI **MicroNode 130 Forward and Return Path RFoG ONU** delivers advanced bi-directional, interactive RF services over a passive fiber optic distribution network. The MicroNode 130 RFoG ONU serves as the optical transport layer for RF video, DAVIC, and DOCSIS technologies in deep fiber and FTTH access networks. This not only eliminates the costs of the annual testing and maintenance required to operate the HFC nodes, but also reduces the ongoing power requirements of nodes and RF amplifiers. The MicroNode provides bi-directional services over extended RF frequencies (up to 1.1Ghz) while being compatible with both headend and customer premises equipment (CPE), and preserving today's operating processes. CTDI's MicroNode 130 RFoG ONU: flexibility to grow your network to meet customer demand now and in the future.

### Benefits

- Reduces network costs via elimination of HFC nodes and amplifiers
- Allows deployment of deep fiber and FTTH distribution networks while leveraging existing RF and DOCSIS investments
- Compatible with headend and CPE equipment
- High performance, ultra low noise burst mode enables use of full RF spectrum for the return path, resulting in increased available bandwidth
- Increased reliability of an all-fiber network
- Reduced power consumption via green technology

### Features

- Extended spectrum RF video
- Analog & digital video formats
- Universal HFC set top box, cable modem and head-end support
- Transparent return path capability (protocol and modulation format agnostic)
- Optical AGC with positive RF up-slope
- Supports in-home applications without amplifiers
- In-home power over coax cabling





# MicroNode™ 130 RFoG ONU

## Specifications

### Physical

- 1.2" H x 3.5" W x 5" D  
3.0cm H x 8.9cm W x 12.7cm D
- Weight: 7.5oz / 0.2kg

### Indicators/External Alarms

- Green LED power indicator
- Red LED loss of signal indicator

### Optical Interface

- 1 recessed SC/APC female fiber connector

### Customer Interface

- 75 ohm coax "F" connector

### Downstream Characteristics

- Input wavelength: 1310nm  $\pm$ 50nm
- Input power range: 0 to -6dBm
- Loss of optical power alarm: < -11dBm
- RF Output @ 550MHz: +18dBmV/ch  $\pm$ 2dBmV
- Frequency response:
  - MNTH133: 50MHz to 1.1GHz
  - MNTH132: 88MHz to 1.1GHz
- Up-tilt 50MHz/88MHz to 1.1GHz: 3dB
- CNR @ -6dBm input power: 48
- CSO @ 0dBm input power: 60
- CTB @ 0dBm input power: 60

### Return Path Characteristics

- Wavelength: 1550  $\pm$ 10nm
- Output power: +2 to +4dBm
- Input dynamic range: +15dBmV to +40dBmV
- Frequency response:
  - MNTH133: 5MHz to 42MHz
  - MNTH132: 5MHz to 65MHz

### Flexible Installation

- Operate on a single PON fiber architecture
- Installs into any CTDI home ONT enclosure
- Temperature-hardened

### Power and Environmental

- Operating temperature: -40°C to +65°C
- Humidity: 5% to 95% non-condensing
- Power input voltage: 10 to 16VDC (12VDC nominal)
- Power consumption: 3 watts max  
2.3 watts typical

### Standards and Certifications

- UL listed, CE mark certified
- Meets or exceeds FCC part 15b
- IEC 608251:1993+A1:1997+A2:2001
- 2004/108/EC
- EN55022, EN55024, EN50083, EN61000-3 & EN60950
- RoHS
- SCTE 55-1, 55-2
- Compatible with DAVIC & DOCSIS

### Ordering Information

Part #	Description
MNTH132	MicroNode 132 RFoG ONU
MNTH133	MicroNode 133 RFoG ONU

### Power

The following CTDI power supplies may be used to operate MicroNode 130 RFoG ONUs.

Part #	Description
PSB8000	APC UPS (Charger & battery) 12 Volt
PSB8002	Hardened APC UPS (charger & battery), 12 volt
PSB1005	Brick, plug-mount, 12 Volt
PSB1006	Brick, International plug mount, 12 Volt
PSB1007	Brick, plug-mount, coax feed, 12 Volt
PSB1008	Brick, International plug mount, barrel plug connector, 12 Volt
PSB1009	Hardened UPS for OSPE202 (120VAC)
PSB1010	Hardened UPS for OSPE202 (240VAC)
BAT1002	UPS battery for OSPE202 and PSB8000 series, 12 Volt

### Mounting

The MicroNode 132 RFoG ONUs may be mounted directly on an interior wall or into any of the following CTDI enclosures.

Part #	Description
OSPE110	Enhanced plastic outside plant enclosure kit
OSPE120	Plastic outside enclosure with NID
OSPE202	All-in-One metal enclosure
OSPE301	MicroNode standard outside enclosure

## Standalone RFoG Architecture

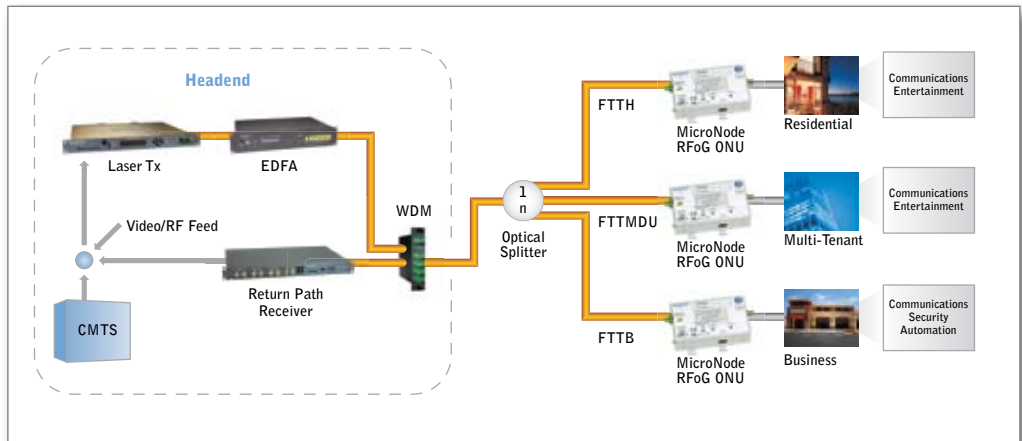

**CTDI**  
PRODUCTS

Communications Test Design, Inc.  
1373 Enterprise Drive • West Chester, PA 19380  
610.436.5203 • www.ctdi.com

©2010 CTDI. All rights reserved.  
Class 1 Laser Products. Information subject to change without notice. • REV042310