



Communications Test Design, Inc.

iMarc[®] 9783 – CSU/DSU

Installation Instructions

Copyright

© Copyright Communications Test Design, Inc., 2008. All rights reserved.

The information contained in this document is the proprietary and/or confidential information of Communications Test Design, Inc. ("CTDI") and is subject to all relevant laws protecting intellectual property and confidential information, as well as to the terms of any specific agreement protecting CTDI rights in such information. Neither this document nor the information contained herein may be published, reproduced, transmitted or disclosed in whole or in part by any means for any purpose without the express, prior, written authorization of CTDI. In addition, any use of this document or the information contained herein for any purposes other than those for which it was disclosed is strictly forbidden.

All specifications and designs are subject to change without prior notice.

CTDI may have patents or pending patents applications, trademarks, copyrights, or other intellectual property rights covering subject matter in this document. The furnishing of this document does not constitute a license to these patents, trademarks, copyrights, or other intellectual property.

Trademarks

Verilink, WANSuite, NetEngine, XSP-100 Shark, Access-T, Mega-T, TerraMux and iMarc are trademarks or registered trademarks of Communications Test Design, Inc. in the United States and other jurisdictions. All other trademarks, registered trademarks and service marks are the property of their respective owners.

Service and Warranty

For assistance with applications or technical questions, please contact CTDI technical support:

Phone: North America 1-888-444-9556

International: +1-615-884-7455

Email: NCservice@ctdi.com

To place an order, please contact CTDI sales:

Phone: 866-953-9030

Email: productsales@ctdi.com

Should a product require repair or replacement, please contact CTDI Customer Service:

Phone: North America 1-888-444-9556

International: +1-615-884-7455

Email: NCservice@ctdi.com

Communications Test Design, Inc.
1353 Enterprise Drive
West Chester, PA 19380
USA

Communications Test Design, Inc. warrants all CTDI products to be free of defects and to be fully functional for the time period beginning with shipment and ending as specified by the terms and conditions governing the sale of the product. Any attempt to repair or otherwise modify the product by anyone other than an authorized CTDI representative will void the warranty. A complete statement of the CTDI warranty policy is available upon request.

April 2009

Document Part Number 9783-A2-GN10-70

Compliance Information

Regulatory – Compliance and Agency Approval

This product complies with or has obtained Regulatory Agency approval at least against the following standards:

- **EMC – Emission** FCC Part 15 (Class A)
- **Safety** UL 60950-0
 CSA C22-2 N°60950-0

Compliance and Regulatory Statements

1. FCC Part 15 Statement

This digital equipment has been tested and found to comply with the limits for a Class A digital device, pursuant to part 15 of the FCC Rules.

These limits are designed to provide reasonable protection against harmful interference when the equipment is operated in a commercial environment. This equipment generates, uses and can radiate radio frequency energy and, if not installed and used in accordance with the instructions, may cause harmful interference to radio communications. Operation of this equipment in a residential area is likely to cause harmful interference, in which case the user will be required to correct the interference at his or her own expense.

2. Industry Canada Statements

This digital equipment does not exceed Class A limits for radio noise emissions for digital apparatus, set out in Radio Interference Regulation of the Industry Canada. Operation in a residential area may cause unacceptable interference to radio and TV reception requiring the owner or operator to take whatever steps necessary to correct the interference.

Users should ensure for their own protection that the electrical ground connections of the power utility, telephone lines and internal metallic water pipe system, if present, are connected together. This precaution may be particularly important in rural areas.



Users should not attempt to make such connections themselves, but should contact the appropriate electric inspection authority, or electrician, as appropriate.

3. Notice d'Industrie Canada

Ces équipements ne dépassent pas les limites de Classe A d'émission de bruits radioélectriques pour les appareils numériques, telles que prescrites par le Règlement sur le brouillage radioélectrique établi par l'Industrie Canada. L'exploitation faite en milieu résidentiel peut entraîner le brouillage des réceptions de radio et de télévision, ce qui obligerait le propriétaire ou l'opérateur à prendre les dispositions nécessaires pour en éliminer les causes.

Pour sa propre protection, l'utilisateur doit s'assurer que tous les fils de mise à la terre de la source d'énergie électrique, des lignes téléphoniques et des canalisations d'eau métalliques, s'il y en a, sont raccordées ensemble. Cette précaution est particulièrement importante dans les régions rurales.



L'utilisateur ne doit pas tenter de faire les raccordements lui-même, mais doit avoir recours à un service d'inspection d'installations électriques ou d'un électricien.

Making Changes or Modifications



Any changes and modifications not expressly approved by CTDI will void any compliance and regulatory approval, and will void the user's authority to operate the equipment.

Safety Warnings and Precautions



Warning
Warnung
Avertissement

<p>Access to the interior of this unit shall be made only by a qualified technician</p> <p>To ensure adequate cooling of the equipment, a 2.0-inch unobstructed space must be provided around all sides of the unit.</p> <p>The AC Power Socket shall be installed near the equipment and shall be easily accessible</p> <p>Remove power plug from the power socket before performing any service on the unit.</p>	<p>Der Zugang ins Innere des Gerätes ist nur einem fachlich qualifizierten Techniker gestattet.</p> <p>Um die Kühlung des Gerätes nicht zu beeinträchtigen, ist es notwendig, an allen Seiten des Gerätes ca 5 cm Raum zu lassen</p> <p>Stellen Sie das Gerät in der Nähe eines geerdeten Schutzkontaktsteckers so auf, dass der Stecker leicht erreichbar und zugänglich ist.</p> <p>Vorm Öffnen des Gerätes muss der Netzstecker yom Stromnetz getrennt werden!</p>	<p>Seul un spécialiste devrait avoir accès à l'appareil</p> <p>Afin de ne pas nuire au processus de refroidissement, il est nécessaire de laisser un espace d'environ 5 cm de chaque côté de l'appareil.</p> <p>Placez l'appareil près d'une prise de courant facilement accessible</p> <p>Débranchez l'appareil avant de l'ouvrir</p>
--	---	--

Contents

- iMarc DSL 9783 CSU/DSU Overview 7
- Upgrading a Unit to the SLM Feature Set. 8
- Product Documentation 8
- Package Checklist 8
- Wiring and Cables You May Need 9
- Prior to Installing the CSU/DSU 10
 - Provisioning Data Circuits in OpenLane 10
- Installing the CSU/DSU 11
- Power-On 14
- Status LEDs 15
- Troubleshooting 16
- Configuration Setup 17
- Verifying that Self-Test Passed 18
- Menu Navigation 19
- Menu Hierarchy 20
- Using the Easy Install Screen 23
- Completing Setup From the NOC 25
- Configuring SNMP Trap Managers and Traps 25
- Verifying End-to-End Management Path 26
- Checking That Data is Being Received 26
- Checking PVC Connections 27

NOTE:

In this document, CSU/DSU refers to the line termination capability of the DSL endpoint, and does not imply association with traditional T1 or subrate equipment.

iMarc DSL 9783 CSU/DSU Overview

The iMarc™ DSL (Digital Subscriber Line) 9783 CSU/DSU is a component in the iMarc system. This system allows you to perform end-to-end service level management across a hybrid iMarc DSL/ATM/Frame Relay network. Service providers can isolate and correct problems remotely from their NOC (Network Operations Center).

The CSU/DSU has an SDSL front end and is a manageable frame relay aware endpoint. A typical example of using the iMarc DSL 9783 CSU/DSU in a network configuration is shown below.

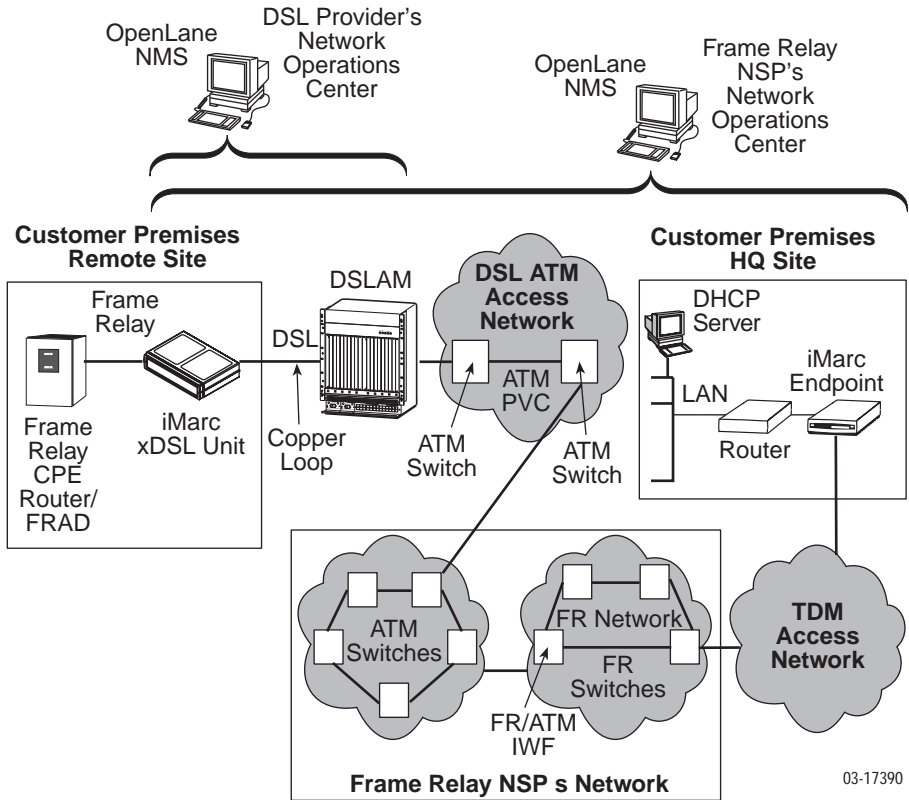

The iMarc DSL 9783 CSU/DSU is available in two feature sets:

- Basic diagnostic feature set provides basic frame relay and diagnostic capability.
- Service Level Management (SLM) provides basic features, plus reporting and monitoring.

Refer to the *iMarc SLV Technical Description* for a list of iMarc DSL features, and the capabilities provided by each feature set.

Upgrading a Unit to the SLM Feature Set

Full Service Level Management (SLM) capability can be activated in units that have the basic diagnostic feature set at any time. This is an optional feature that adds real-time and historical network performance monitoring and SLA (Service Level Agreement) reporting capabilities to your iMarc unit and network. To activate SLM, order a Feature Activation Certificate. You can order the certificate for a single unit or for many units.

OpenLane SLM Release 5.3 or above is required to schedule activation of SLM features in units, and to manage the number of activations remaining on the certificate. OpenLane also provides a Certificate Summary Report to assist you in the management of the certificate.

When the Feature Activation Certificate arrives, add the Activation Certificate Number to your OpenLane SLM application's database. Activations can occur at any time, for as many units as desired, until no activations remain for the certificate.

Contact your sales representative for additional information.

Product Documentation

The complete product documentation is available at www.ctdi.com/ProductsPortfolio/tabid/2475/Default.aspx

Select the following documents:

- 9000-A2-GB30, *iMarc Technical Description*
- 9000-A2-GB31, *iMarc Configuration Reference*
- 9000-A2-GB32, *iMarc SNMP Reference*
- 9000-A2-GB33, *iMarc Operations Guide*

Package Checklist

In addition to these instructions, verify that your package contains the following:

- iMarc DSL 9783 CSU/DSU
- Power cord with power transformer
- Tie wrap for power cord strain relief
- DSL network access cable with 8-pin connectors – U.S. models only
- Ferrite choke – International models only

Wiring and Cables You May Need

The following wiring and cables are used with this product, which uses standard interface connectors:

- Standard connectors: An 8-pin modular (similar to RJ48C) or 6-pin modular (similar to RJ11) wall jack for the DSL network connection.
- DSL wiring: Unshielded twisted-pair wiring (CAT3, or better). The CAT3 wiring must meet EIA/TIA-568 specifications with 24 AWG (.5 mm) or 26 AWG (.4 mm).
- Ethernet wiring: Shielded twisted-pair wiring (CAT5, or better). The CAT5 wiring must meet EIA/TIA-568 specifications with 24 AWG (.5 mm) or 26 AWG (.4 mm).

Interface Connection	Cables	Feature Number
COM port to a PC or asynchronous terminal	DB25-to-DB25: Standard EIA-232 straight-through cable	—
	DB25-to-DB9: <ul style="list-style-type: none"> ■ DB25-to-8-pin modular adapter ■ 8-pin modular-to-DB9 cable (14 feet – 4.3 m) 	3100-F1-920 3100-F2-550
ETHERNET port to a NIC on a PC or an Ethernet hub	For connection to a PC NIC: Standard Ethernet crossover cable	—
	For connection to an Ethernet Hub: Standard Ethernet straight-through cable	—
User data PORT to a DTE	Standard V.35 straight-through cable	—
NETwork to the DSL wall jack	Standard straight-through DSL network cable with 8-pin modular connectors – similar to an RJ48C-to-RJ48C cable (20 feet – 6.1 m). <i>Cable supplied for use in the U.S.</i>	3100-F1-500
	Standard DSL network cable with 6-pin connectors – similar to an RJ11 cable	—

Prior to Installing the CSU/DSU

These Installation Instructions require that the virtual circuits at the DSLAM have already been configured. Provisioning of these circuits can be simplified by using the OpenLane SLM (Service Level Management) system.

Provisioning Data Circuits in OpenLane

Use the OpenLane SLM system's Provision Circuit screen to add new circuits that start at the iMarc DSL endpoint and traverse the SCM and ATM line card in the Hotwire GrandSLAM, and the default VC sets (from 1 to 4). A group of 250 VCs can be allocated to each line card, which can be assigned to any port on the card. These custom connections carry the frame relay traffic.

- Note that before the custom cross-connects are configured, the Maximum VCI number for the uplink VP to be used by these custom connections must be specified on the Max VCI per VPI screen, and the **apply changes** executed.
- For ATM line cards, custom connections can be used to expand the number of VCs connected to the card. Each of the 250 VCs can be cross-connected from any VC on the uplink to any port on the line card.

The following information is collected by the Provision Circuit process:

- Uplink VPI/VC
- Slot number and Port number of the DSL connection
- Traffic Profile
- DSL link VPI/VC
- Frame relay DLCI (provided by NSP)
- Frame relay CIR, B_e, B_c (provided by NSP)

A Circuit ID is then applied to the newly defined circuit, and stored in both the CSU/DSU and the OpenLane SLM system.

Installing the CSU/DSU

Place the iMarc DSL 9783 CSU/DSU on a flat surface with clearance for the rear connectors.

► Procedure

1. Use the supplied 8-pin DSL network cable (for use in the U.S.), or a 6-pin DSL network cable (using connectors similar to RJ11), as applicable, for the DSL connection. Insert one end of the cable into the jack labeled NET. Insert the other end into the wall jack for DSL data communications.

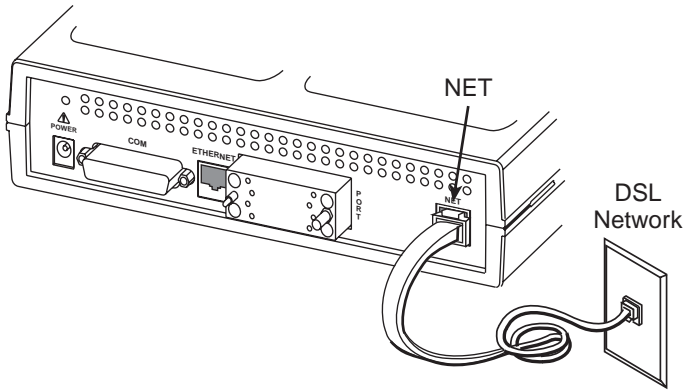

01-16774-02

For domestic models, go to [Step 3](#) on page 12.

2. For certain international models, a ferrite choke has been provided. Place the ferrite choke on the network cable, as close as possible to the rear panel.

Close the two halves around the cable and snap the latch shut.

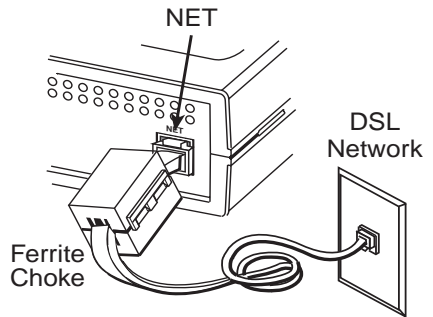

01-16944

-
3. Use an 8-pin Ethernet cable for the Ethernet connection for local management. Insert one end of the cable into the jack labeled **ETHERNET**.
- Use a straight-through cable to connect the other end of the cable to an Ethernet hub. Do not connect to the hub's optional Uplink connection with a straight-through cable; the Uplink connection requires an Ethernet crossover cable.

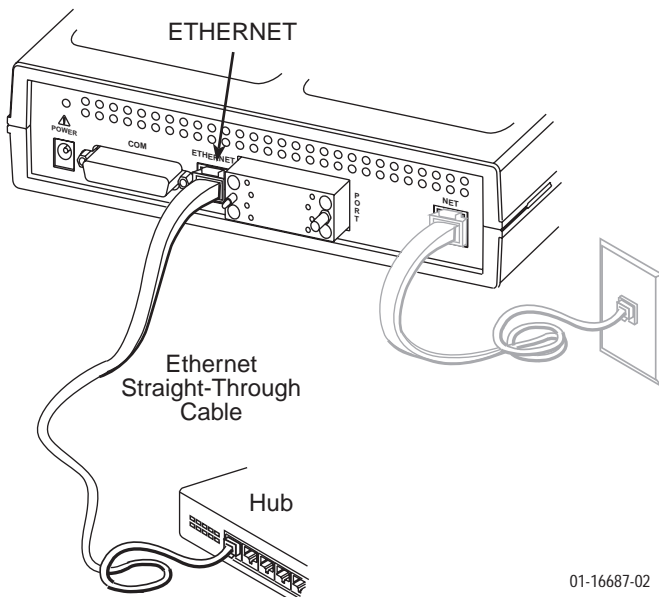

01-16687-02

— or —

- Use an Ethernet crossover cable to connect to a PC with an Ethernet Network Interface Card (NIC) installed or a hub's Uplink connection.

4. Connect one end of the DTE's cable to the user data port labeled PORT. Plug the other end of the cable into the DTE (router or FRAD). Tighten the screws on each side of the connector.

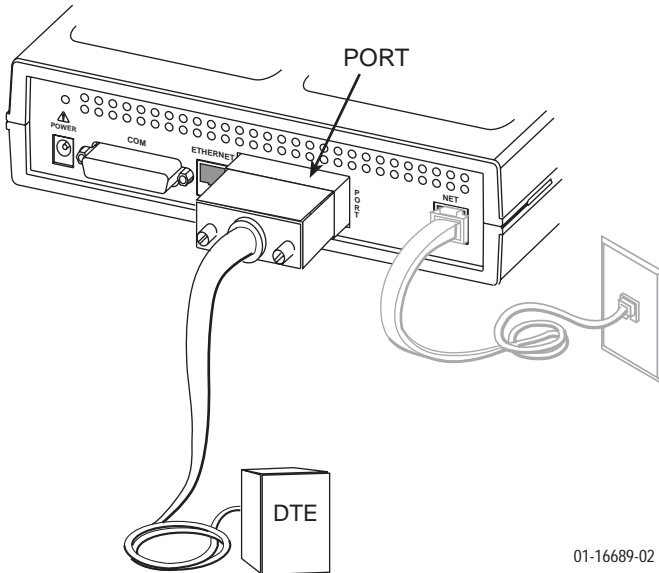

01-16689-02

5. Use a VT100-compatible asynchronous terminal or a PC to set up management access to the unit. Insert the DB25 end of the EIA-232 cable into the CSU/DSU's COM port. Tighten the screws on each side of the connector. Insert the other end of the cable into the terminal or PC.

The terminal or PC's configuration must be compatible with the CSU/DSU's. Refer to [Configuration Setup](#) on page 17.

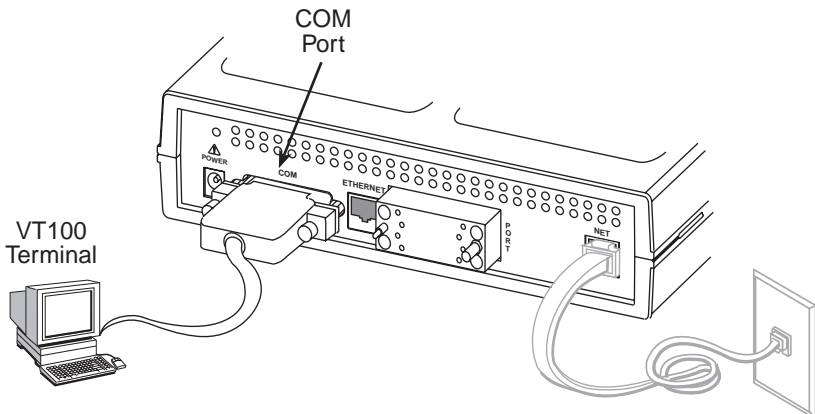

01-16685-02

6. Insert the supplied power cord's round end into the jack labeled POWER. Plug the transformer into an AC outlet.

Install the supplied tie wrap for strain relief, as shown.

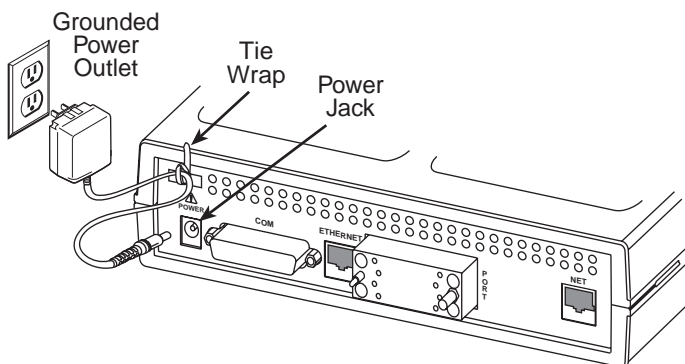

01-16773-02

Installation of the hardware is now complete. When the power cord is installed, the CSU/DSU goes through a power-on self-test.

Power-On

When power is applied, the CSU/DSU performs self-diagnostics and the PWR LED is on. The self-diagnostics include a power-on self-test where all of the LEDs are on.

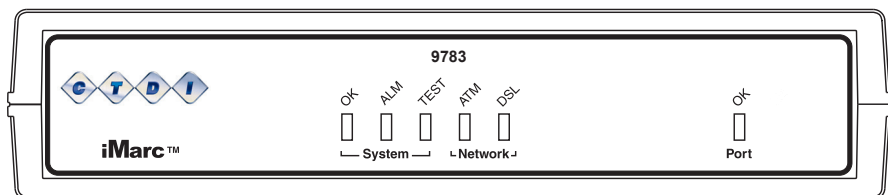

Refer to [Status LEDs](#) on page 15 for information about the LEDs. Refer to [Troubleshooting](#) on page 16 for LED indications requiring action.

Status LEDs

After a successful self-test, the LEDs should appear as indicated in **BOLD** in the Condition column below.

LED	Condition	Status
System LEDs		
OK	ON	The CSU/DSU has power.
ALM	ON	An alarm condition exists.
	OFF	No alarms have been detected by the CSU/DSU.
TEST	ON	The CSU/DSU is performing the power-on self-test, or a test initiated by the service provider is currently active.
	OFF	No tests are active.
Network LEDs		
ATM	ON – Green	ATM LED is active and cell delineation is in sync.
	ON – Yellow	ATM mode is active and there is loss of cell delineation.
	OFF	The ATM link is not active.
DSL	Blinking	The CSU/DSU is in start-up or is retraining. The LED blinks on and off about five times per second.
	ON	The DSL link is ready to transmit and receive data.
	OFF	No DSL link has been established, or the link is down.
Port LED		
OK	ON	The user data port is transmitting and receiving data.
	OFF	The user data port is idle. This occurs when the port is: <ul style="list-style-type: none"> ■ Disabled, or ■ Configured to monitor DTR and/or RTS, and the lead is not asserted.

Troubleshooting

LED Symptom	Action
All LEDs are on.	If the LEDs remain on for more than ten minutes, the CSU/DSU is not functional. Unplug the unit and reapply power. If the ALM LED is still on, contact the service provider.
ALM LED only remains on.	The power-on self-test may have failed. Unplug the unit and reapply power. If the alarm LED is still on, contact the service provider.
ALM and TEST LEDs are blinking.	Firmware download may be in progress. If firmware download is not in progress or the LEDs continue blinking for more than ten minutes, contact the service provider. <i>Do not unplug the unit, unless instructed to do so by the service provider.</i>
ATM Yellow LED remains on.	There is loss of cell delineation (OCD) due to line impairments. Contact the service provider.
DSL LED is off.	Verify that the DSL cable is securely installed on both ends. Unplug the unit and reapply power. If the problem continues, contact the service provider.
DSL LED continues blinking after the power-on self-test has completed.	The unit is attempting to establish the DSL link, or adjusting the DSL line rate due to line conditions. If the blinking continues for more than ten minutes, contact the service provider.
DSL LED is on, but no data is being transmitted.	The DSL link has been established, but there is no data transmission. Verify the Ethernet connection. If the problem persists, contact the service provider.
DSL and Port LEDs are on, but no data is being transmitted.	DSL and Ethernet links have been established, but there is no data transmission. If the problem continues, contact the service provider.
Port LED is off.	Verify that the Ethernet cable is securely installed at both ends, and at least one PC is connected and powered on.
	Verify that the correct Ethernet straight-through or crossover cable is installed. Refer to Step 3 on page 12.
System OK LED is off.	Check that the power cord is securely installed on both ends.
	If no LEDs are on, the power supply may be defective. Test the outlet to verify power. If the outlet has power and the problem persists, contact your service representative.
	If other LEDs are on, the OK LED may be burned out. Unplug the unit and reapply power, and watch all LEDs as the unit performs its power-on self-test. If the OK LED is functioning, call your service representative.
TEST LED is on.	A test initiated by the service provider may be active. Wait ten minutes. If the LED does not go off, contact the service provider.

Configuration Setup

Once the CSU/DSU is installed, it can be accessed locally through the menu-driven user interface via an asynchronous terminal or PC connection, or remotely via a Telnet session. The following provisioning can be set up:

- **Frame relay, ATM, and physical layer provisioning** – Typically set up by the CLEC (Competitive Local Exchange Carrier) using the menu-driven user interface via an ASCII terminal or PC running a terminal emulation program, or a Telnet session.
- **SLM provisioning** – Typically set up by the frame relay service provider or the CLEC.

As soon as the CSU/DSU's COM port is connected to a terminal or PC, the menu-driven user interface can be accessed. The terminal or PC's configuration must be compatible with the router's COM port settings.

► Procedure

To access the menu-driven user interface:

1. Verify the terminal or PC's configuration:
 - Data Rate is set to 19.2 kbps.
 - Character Length is set to 8 data bits.
 - Parity is set to None.
 - Stop Bits is set to 1.
 - Flow Control is set to None.
2. Press Enter to display the Main Menu.

main

Device Name: Node A

9783-C-SLV

2/26/2001 00:02

MAIN MENU

Status

Test

Configuration

Control

Easy Install

Ctrl-a to access these functions

Exit

If the Main Menu does not appear, recheck the terminal or PC's settings, or press Enter again. Refer to *Troubleshooting* in the *iMarc SLV Operations Guide* for other explanations.

Verifying that Self-Test Passed

To verify that the unit passed its self-test, go to the System and Test Status screen.

Main Menu → *Status* → *System and Test Status*

The results of the self-test appear directly under the screen title.

If any failure messages appear, reset the unit by disconnecting, then reconnecting the power cord. The unit will perform the self-test again. If the failure reappears, call your service representative for assistance.

Menu Navigation

The CSU/DSU should operate using the default (factory-set) configuration options. Refer to the following table for help in navigating the menus.

Press the . . .	To . . .
Esc key	Go back one screen or menu level. See Menu Hierarchy on page 20.
Tab key, and Up (↑), Down (↓), Left (←), Right (→) Arrow keys	Move the cursor from one menu item to the next.
Enter or Return key	Complete the menu or option selection.
Spacebar	Display the next available setting when changing a configuration option. All the available settings for an option appear at the bottom of the screen.

As an example, follow these steps to go to the Configuration Edit/Display menu so you can start setting up the unit.

► Procedure

To load a configuration for editing:

1. From the Main Menu, press the Tab key twice, or press the down (↓) arrow twice, so the cursor is on Configuration.
2. Press Enter to select Configuration. The Load Configuration From menu appears.
3. Press Enter to select Current Configuration (the cursor is already on this selection). The Configuration Edit/Display menu appears.

This sequence of steps would be shown as the menu selection sequence:

Main Menu → Configuration

► Procedure

To save configuration changes:

1. Press Ctrl-a to switch to the function keys area at the bottom of the screen.
2. Type **s** (Save) and press Enter. The Save Configuration To menu appears.
3. Press Enter again to save your changes to the Current Configuration (the cursor is already on this selection).

To continue configuring the CSU/DSU, press Esc until the Configuration Edit/Display menu reappears. To return to the Main Menu, press Ctrl-a, type **m** (MainMenu), and press Enter.

Menu Hierarchy

The Menu Hierarchy shows the organization of the iMarc unit's screens.

Status	System and Test Status	Self-Test Results Last Reset Health and Status Test Status
	IP Path Connection Status	Device Name IP Address Status Discovery Source
	PVC Connection Status	Source Link, DLCI, EDLCI Primary Destination Link, DLCI, EDLCI, Status
	Network Interface Status	Operating Rate Receiver Attenuation SNR Margin
	IP Routing Table	Destination Mask Gateway Hop Type Interface TTL
	Performance Statistics	Service Level Verification DLCI Frame Relay ATM VCC Ethernet Clear All Statistics
	Trap Event Log	Number of Trap Events Time of Day Event
	Display LEDs and Control Leads	
	Identity	System NAM

Test	Network PVC Tests	PVC Loopback
	Data Port PVC Tests	Send Pattern Monitor Pattern Connectivity
	Data Port Physical Tests	DTE Loopback
	Network ATM Loopback Tests	ATM Ping
	IP Ping	
	Lamp Test	
	Abort All Tests	

Configuration	System	Frame Relay and LMI PPP Class of Service Definitions Service Level Verification General
	Network	Physical
	Data Ports	Frame Relay PPP Circuit Records ATM
	Data Ports	Physical Frame Relay DLCI Records
	PVC Connections	Source Link, DLCI, EDLCI Primary Destination Link, DLCI, EDLCI
	IP Path List	Add and Display Static Paths
	Management and Communication Options	Node IP Management PVCs General SNMP Management Telnet and FTP Sessions SNMP NMS Security SNMP Traps Ethernet Management Communication Port Modem Port

Control

System Information	Device Name System Name, Location, Contact Date Time
Administer Logins	Login ID Password Access Level
Change Operating Mode	Back-to-Back Mode Standard Mode
Select Software Release	Current Release Alternate Release Switch & Reset
LMI Packet Capture Utility	Capture Interface Packet Capture Start/Stop Status Packets in Buffer Display LMI Trace Log
Telnet	
Reset Device	

Easy Install

Service Type
DSLAM Type
Node IP Address
Node Subnet Mask
TS Access
Create Dedicated Network Mgmt Link
Ethernet Port Options Screen
Network 1 DSL Line Rate
Network 1 FRF.8 Encapsulation Mode

Using the Easy Install Screen

An Easy Install screen is provided for custom configurations, but is not required for normal installation. You can configure the router by making selections from the Configuration Edit/Display menu.

► Procedure

1. Select the Easy Install feature.

Main Menu→*Easy Install*

Easy Install Screen Example

```
main/easy_install                               9783-C-SLV
Device Name: Node A                             2/26/2001 00:01

                                EASY INSTALL

DSLAM Type:                                Paradyne_____

Node IP Address:                            000.000.000.000  Clear
Node Subnet Mask:                           000.000.000.000  Clear
TS Access: VPI,VCI                           0,35

Create a Dedicated Network Management Link
Ethernet Management Options Screen

Network 1 DSL Line Rate (Kbps)                AutoRate
Network 1 FRF.8 Encapsulation Mod             Transparent

-----
Ctrl-a to access these functions, ESC for previous menu   MainMenu  Exit
Save
```

-
2. If the CSU/DSU will not be connected to a Paradyne DSLAM, change the DSLAM Type. Other selections are Alcatel (NewBridge), PairGain, and Nokia.
 3. Enter the Node IP Address and Node Subnet Mask.
 4. Specify TS Access if a Troubleshooting (TS) DLCI or Virtual Circuit (VC) is being set up for remote access by the service provider. The default is 0,35.
 5. Select Create a Dedicated Network Management Link to set up for permanent remote access by the NOC. Enter a DLCI, VPI, and VCI at the resulting prompts.
 6. If Ethernet management will be used, select Ethernet Management Options Screen to go directly to the Ethernet Management Options input screen.
 - Enable the interface (Status).
 - Respond Yes to the prompt `Would you like to set the Node's Default IP Destination to Ethernet?`
 - Enter the IP Address and Subnet Mask for the Ethernet interface.
 - Enter the Default Gateway Address (the IP Address that will be used for packets without a specified route).
 - Enable Proxy ARP, or leave it disabled.
 - Press the Esc key to return to the Easy Install screen.
 7. Change Network 1 DSL Line Rate (Kbps), if desired. The default is AutoRate.

If a Paradyne DSLAM is used, the default setting is AutoRate. For non-Paradyne DSLAMs, the AutoRate setting is not valid and the default rate is 784 kbps.
 8. Change Network 1 FRF.8 Encapsulation Mode, if desired. The default is Transparent (data is forwarded without translation), which supports both frame relay and ATM PVCs, and iMarc proprietary multiplexing.
 9. Save the configuration.

Completing Setup From the NOC

► Procedure

1. Access the remote CSU/DSU on the TS Management Link that was set up at the remote site in [Step 5 of *Using the Easy Install Screen*](#).
2. Ping the CSU/DSU five times within five seconds. The unit automatically provisions the TS Access VC and accepts the destination IP address of the Ping as its temporary IP address, which is used on the management VC interface.
3. If necessary, open a Telnet session and configure any specific configuration options that require input or changes from default settings. Create all customer VCs, including internal DLCIs and VPI/VCI on the DSL interface, and cross-connect the DLCIs to the VCCs.

Configuring SNMP Trap Managers and Traps

► Procedure

To enter SNMP managers and configure traps:

1. Select SNMP Traps.

Main Menu → Configuration → Management and Communication → SNMP Traps

2. Configure the following:
 - Enable SNMP Traps.
 - Identify the total Number of Trap Managers.
 - Specify the IP address for each NMS Trap Manager to which traps will be sent.
 - Specify the Initial Route Destination for each Trap Manager. The default is AutoRoute.
 - Select or disable trap categories, as needed.
3. Save the configuration.

Verifying End-to-End Management Path

After installation of a remote CSU/DSU, run an ATM Ping test from the Hotwire® GranDSLAM.

► Procedure

To Ping the router:

1. From the Hotwire 8335 ATM Line Card's Main Menu, select the ATM Ping test.

Diagnostics → *ATM Ping (D-C)*

2. Enter a VPI of 0 and a VCI of 35.
3. Select Towards the Endpoint, then Start.
4. If the test is successful, select Towards the Network, then Start.

If both tests are successful, the VC has been tested from end to end.

For additional information on the Hotwire ATM Line Card, refer to the *Hotwire ATM Line Cards, Models 8335 and 8365, User's Guide*, Document No. 8335-A2-GB20.

Checking That Data is Being Received

► Procedure

To verify that data is being received:

1. From the unit's Main Menu, select either interface's frame relay statistics.

Main Menu → *Status* → *Performance Statistics* → *Frame Relay* → *Net1-FR1*

2. Repeatedly Refresh the screen to:

- Verify that the counts for Frames Received and Characters Received under the Frame Relay Link statistics are increasing.
- Verify that there are no errors under Frame Relay Errors.

If data is not being received or you are receiving errors, check your cable connections and replace or repair a damaged cable.

3. Return to the Status menu.

Checking PVC Connections

Check PVC connections to verify that all PVCs, including management PVCs, are configured and active.

► Procedure

To verify PVCs:

1. Select PVC Connection Status from the Status menu.

The PVC Connection Status screen shows all PVC connections, the interface source and DLCI number of the incoming data linked to the interface, and DLCI number for the outgoing data. You can also see whether the PVC is active.

2. Verify that each PVC is active.
 - If active, the unit should be passing data.
 - If not active, no data traffic can be carried by the PVC. If the PVC is configured correctly, the circuit may be down.

